

Coronation Home Learning Challenge



Part 1: Design a Special Stamp (1 CU credit)

Did you know, Royal Mail designs and issues special or 'commemorative' stamps to mark a special occasion? Many people from all over the world collect stamps (they're called 'Philatelists'), and so to mark King Charles III's coronation, we'd like you to design a special stamp.

Step 1: Think about your design. Stamps usually have a picture of the King or Queen's head on, but the special stamps don't always have this. They might have a picture of something that represents the special occasion, some scenery or even a pattern. Here are some examples to give you an idea, or you could research them online? Will yours be straight or rectangle? Will they include crowns, London buses, London landmarks perhaps?

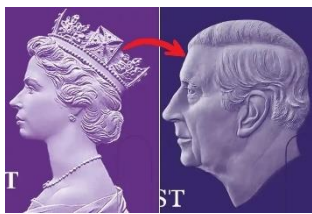

Step 2: Think about colour. Stamps are rarely black and white, but the new one for King Charles III is in a blue shade. You might think the colour ones are more attractive? It's your design – it's up to you!

Step 3: Get designing! Use a piece of paper at least half of an A4 size sheet, so your beautiful art work is big enough for us to see. You might want to use art techniques such as shading, Blending, shadows, texture, etc.

Step 4: Collect your CU credits! Once you've completed as many Coronation Home Learning Challenges as you wish, fill in our sheet at the back of this document. Ask an adult to send the sheet and photos of your learning into us CU@sheffield.gov.uk so we can award your CU credits.

Which Skills Builder skills will I be developing in this challenge?

Main



Others



Coronation Home Learning Challenge



Part 2: Explore Coronation History (2 credits)

There is SO much history and tradition involved in a coronation! Did you know that a very special stone (The Stone of Destiny) has been moved all the way from Scotland to be a part of the King's coronation? There's a history of using the same chairs, the same gowns or cloaks, and of course, the same crown! We'd like you to dig deep into Britain's history, and see if you can find out some of the best facts about the history and traditions.

Step 1: Do some research into coronations in the past. You could visit your local library for this Or you could research the internet. Some good websites might be BBC Newsround (<https://www.bbc.co.uk/newsround/64363584>), Kiddle (<https://kids.kiddle.co/Coronation>), or The Royal Collection (<https://www.rct.uk/discover/school-resources/school-resources-for-the-coronation-2023>)

Step 2: Make a few notes as you go. Can you tell a grown up some of the most interesting facts you have found? Were there any facts they didn't know? Have a think about how you will present your new knowledge. Will you create a leaflet? Could you ask an adult to film you, as if you were a newsreader on the day? Could you create a poster full of facts and pictures? Perhaps you could create a quiz to give to adults – how many questions do you think they'll know?



Step 3: Get creative! Turn your research into your finished piece. See if you can tick off any of your facts if they're mentioned on the coronation day on TV or radio?

Step 4: Collect your CU credits! Once you've completed as many Coronation Home Learning Challenges as you wish, fill in our sheet at the back of this document. Ask an adult to send the sheet and photos of your learning into us CU@sheffield.gov.uk so we can award your CU credits.

Which Skills Builder skills will I be developing in this challenge?

Main



Others



Coronation Home Learning Challenge



Part 3: Cook a Coronation Dish (2 CU credits)

Have you heard of Coronation Chicken? This is a dish containing cold, cooked Chicken, mixed with mayonaisse and curry. This dish was first prepared for the banquet of the coronation of Queen Elizabeth II in 1953. However, Coronation Chicken may have been inspired by Jubilee Chicken, a dish prepared for the silver jubilee of George V in 1935, which mixed chicken with mayonnaise and curry. Coronation Chicken can be served as a tasty sandwich filler, or perhaps with salad, or our favourite, with a crunchy jacket potato! Why not ask an adult to help you create your own Coronation Chicken? Don't worry, you can use a meat alternative or vegetable if you don't eat chicken. Remember to wash your hands at every step.



Step 1: Ask an adult to help you cut 500g chicken breast into small pieces. Top tip: use a clean set of scissors if the knife is too tricky to handle.

Step 2: Ask an adult to help you to gently fry your chicken pieces in a little oil until cooked (no pink bits in the middle of the chicken pieces). Once cooked, let your chicken cool.

Step 3: In a bowl, mix 6 tbsp mayonnaise, 2-3 tsp mild curry powder and a pinch of black pepper together. You could also add ½ tsp ground cinnamon, 2 tbsp of mango chutney and a few sultanas for some extra flavour if you wish.

Step 4: Add the sauce to your cooled, cooked chicken pieces and stir well to make sure it's coated. Serve as you want to – sandwich filling, with salad or in a jacket potato as just a few ideas. We Can't wait to see your creations – do you like it? We wonder if the Royal Family be eating some?

Step 5: Collect your CU credits! Once you've completed as many Coronation Home Learning Challenges as you wish, fill in our sheet at the back of this document. Ask an adult to send the sheet and photos of your learning into us CU@sheffield.gov.uk so we can award your CU credits.

Which Skills Builder skills will I be developing in this challenge?

Main

Others



Coronation Home Learning Challenge



Part 4: Coronation Crafts (2 CU credits)

As with most special occasions, people put up decorations to create a great atmosphere. The streets of London will be filled with flags, banners and all kinds of decorations for the coronation of King Charles III. We wonder whether they'll have decorated Buckingham Palace for the occasion? We'd like you to create your own decorations and perhaps you could create and send a card of congratulations to His Majesty the King and the Queen Consort?

Step 1: Bunting! You can use our template on the next page if you wish to design and decorate the triangles which will eventually be made into bunting. What colours might you use? Will your bunting have a theme, such as the Union Flag? Will it have any letters, words or messages on?



Step 2: Once you've created all your triangles, carefully cut them out. You might need to ask an adult for help if you need it. Carefully push a pencil through the hole shapes at the top corners of each triangle.

Step 3: Thread some string or wool or thread through the holes of each triangle (make sure they're in the right order first!). Hang up your bunting.

Step 4: Now it's time to create a card. You can use simple paper or card if you have it. What pictures might you draw? Make them bright and colourful. Then think about what message you'd like to write inside to His Majesty the King and Her Majesty the Queen Consort. Remember to put your name and address inside in case they're able to send a reply!

Step 5: Ask an adult to help you post off your card – remember a stamp. Here's the address: His Majesty The King, Buckingham Palace, London, SW1A 1AA

Step 6: Collect your CU credits! Once you've completed as many Coronation Home Learning Challenges as you wish, fill in our sheet at the back of this document. Ask an adult to send the sheet and photos of your learning into us CU@sheffield.gov.uk so we can award your CU credits.

Which Skills Builder skills will I be developing in this challenge?

Main

Others



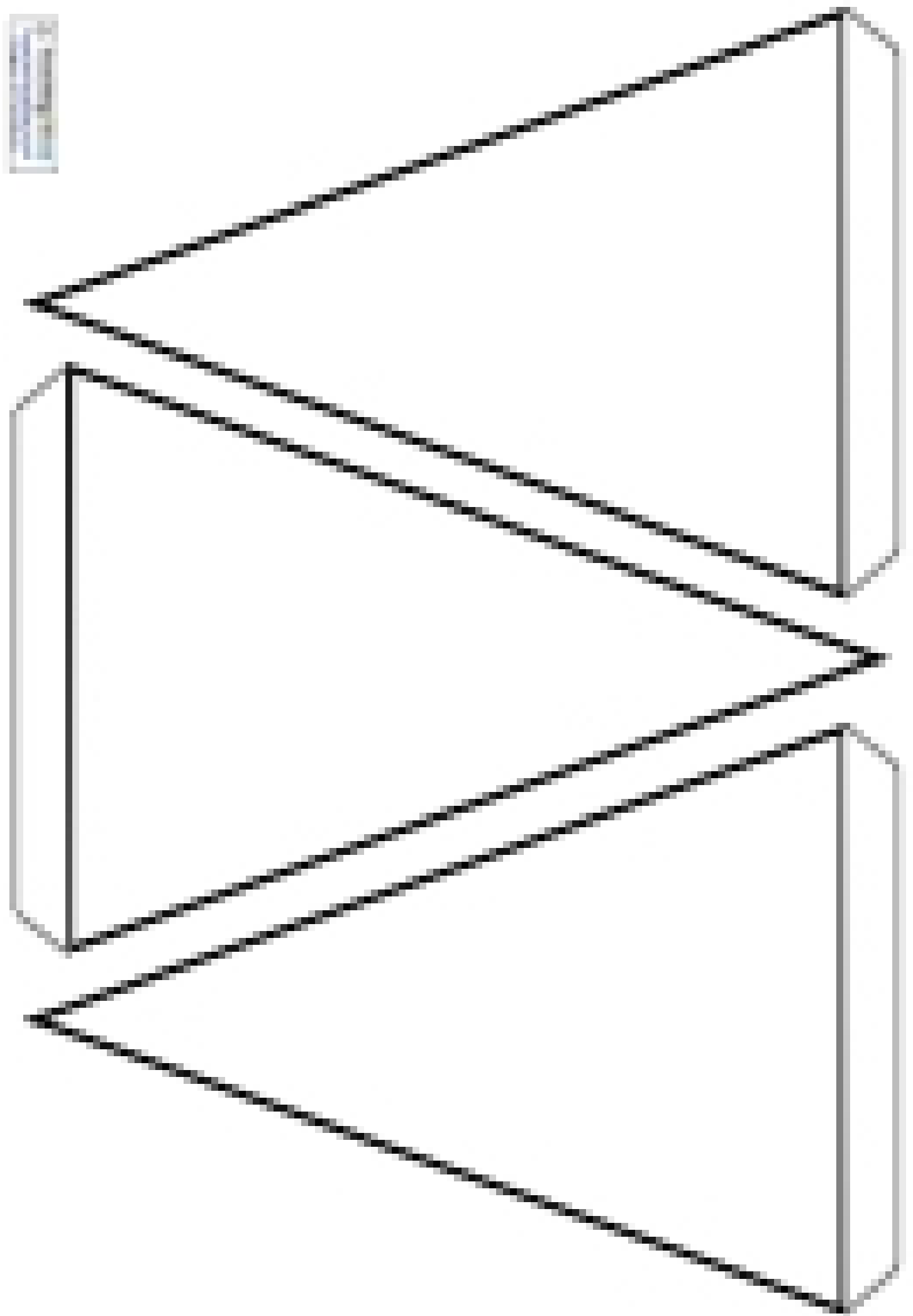

Coronation Home Learning Challenge



Part 5: The Big Help Out (3 CU credits)

To mark His Majesty The King's Coronation thousands of organisations across the country are getting together to give us all the chance to help out in our own local communities. Starting on Monday 8th May there will be opportunities for everyone to join in. No matter what you are good at, there'll be something to suit helping hands of all shapes and sizes! From checking in on someone who'd like a bit of company or volunteering for a charity the more of us who join in, the bigger help we will be. If you can spare an hour...fantastic. The day?...amazing. If it becomes a regular thing, so much the better. If we all do a bit, it will really help a lot. Remember, you MUST ask a grown up's permission before you offer to help out – even better, take them with you so they can help too!

Step 1: Visit the official website to find volunteering opportunities close to you: www.thebighelpout.org.uk Adults can even download the official App to their smart phone.

Step 2: Take the quiz to find the right kind of volunteering opportunities near to you. Don't worry if you can't find anything that's quite right. Why not ask an adult if there are any jobs you could do to help them out? Perhaps it might be tidying the garden, helping them with the shopping? Perhaps you could take a walk around your local area and do a litter pick on the way? Do you have any elderly neighbours that you and your adult could speak to, to see if you can help them in any way?

Step 3: Once you've decided, get going! Make sure you take some photos or video of you taking Part in the Big Help Out. We'd love to see them.

Step 4: Afterwards, decide whether this was a 'one-off' or might you carry on with your volunteering role in the future. Fill in the sheet on the next page to tell us about your special Big Help Out volunteering role – how did you feel? What did you learn?



Step 5: Collect your CU credits! Once you've completed as many Coronation Home Learning Challenges as you wish, fill in our sheet at the back of this document. Ask an adult to send the sheet and photos of your learning into us CU@sheffield.gov.uk so we can award your CU credits.

Which Skills Builder skills will I be developing in this challenge?

Main

Others



My Big Help Out Journal

My name: _____

My date of birth: _____

My school: _____

My adult helper's name: _____



I decided to help out in the following way:

I decided to do this because:

Taking part in the Big Help Out made me feel:

Skills and new things I learned by taking part in the Big Help Out were:

Please share your learning challenges with your school coordinator who will award your learning stamps.
You could send some photos of you in the Big Help Out too!

Coronation Home

Learning Challenge

How to claim your CU credits

To claim your CU credits, you MUST complete this sheet and share this with the Children's University Coordinator in your school or send to admin@essexchildrensuniversity.co.uk or manager@suffolkchildrensuniversity.co.uk

Child's full name: _____

Child's school: _____

Which challenges have you completed? Remember to provide evidence of each Challenge Activity (photos are great!)?

Tick for 'yes'

Challenge 1: Design a Special Stamp (1 CU credit)

Challenge 2: Explore Coronation History (2 CU credits)

Challenge 3: Cook a Coronation Dish (2 CU credits)

Challenge 4: Coronation Crafts (2 CU credits)

Challenge 5: The Big Help Out (3 CU credits)

Total number of CU credits you are claiming: ____ credits (max 10)

